



Streamlined for Success

One of the fastest growing businesses in Cincinnati, TSS Technologies has incorporated Ashlar-Vellum™ software to meet the requirements of a growing customer base.

Since 1948, TSS has grown from a machine shop to a full service manufacturing company employing over 300 people. A key element in the company's success is its ability to consult with customers during the design phase of a product—whether it's the design of an individual part or a high-volume order.

TSS defines itself in terms of diversity—diversity of products and diversity of clients. To serve their customers from businesses in the medical, aerospace, automotive, consumer, and packaging industries, TSS designers use Ashlar-Vellum's solid modelling program, Argon™. Argon enables designers and clients to consult throughout the design process. Argon also facilitates file sharing from other sources. TSS designers find that of Ashlar's extensive translation capabilities, they most often work in IGES and Parasolid.

“Argon is our software of choice—there is very little training required before our new team members are productive on the program. It is amazing how quickly people grow and learn with Ashlar-Vellum.”

Jason Pippenger, TSS Manufacturing engineer and manager for Plant 1, has high praise for Argon. He finds that Argon is an ideal tool for designing in 2D and 3D. The software uniquely fits the company's CAD requirements. It is both easy to use and quick to learn. Designers don't have to spend an inordinate amount of time over drawings, so this speeds up the workflow.

As a result of a recent partnership with a company from the UK, TSS Packaging/Regal North America offers a complete system for filling and sealing preformed containers for foods, pharmaceuticals, and sheets. As a single source supplier, TSS supplies filling and sealing equipment and integrates manufacturing systems throughout the entire plant. Regal North America has designed a range of filling systems to handle a diversity of products. Ashlar is proud to be a part of TSS successful response to quick-changing markets and demanding customers' production schedules.

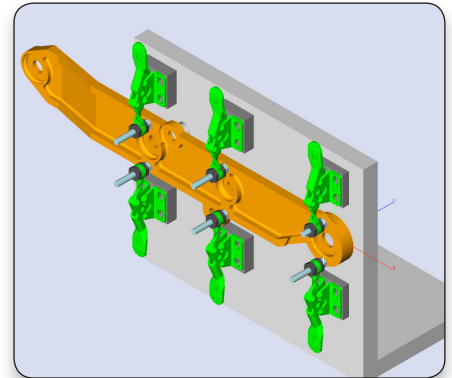

TSS Technologies uses Ashlar-Vellum software to streamline the development process. Designers at TSS find Ashlar-Vellum's extensive translation capabilities speed their time to market.

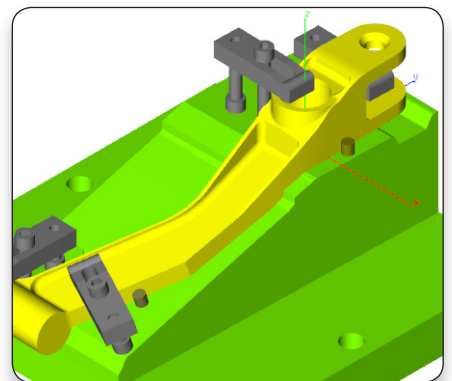

With Argon as part of the workflow, TSS serves customers in the medical, aerospace, automotive, consumer, and packaging industries.

Background/Contact

For more details on this project contact:

Bob Meyer
TSS Technologies

1201 Hillsmith Dr.
Cincinnati, OH 45215

Phone: (513) 772-2938

E-mail: meyer@tsstech.com

Website: www.tss.com